



Fort Worden Welcome Dance

October 4, 2024

JOIE DE VIVRE

(J8x32) 3C (4C set) Irene van Maarseveen, RSCDS Book 39

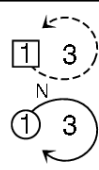
- 1- 8 1s set, cast 1 place, 1s dance down between 3s and cast back to 2nd place on own sides
- 9-16 2s+1s+3s turn RH and chase ½ way round clockwise
- 17-24 3s+1s+2s dance DoSiDo, set and ½ turn partners RH for Allemande
- 25-32 3s+1s+2s dance Allemande. 213

JOIE DE VIVRE						8x32 J
S 		2 1 3 T_R	2 1 3 	3x 1x 2x D	3x 1x 2x S T_R¹/₂	3 1 2 A



Irene van Maarseveen, 1996, RSCDS Book 39.2, RSCDS Thirty Popular Dances Vol 2

3C/4C longwise set.

AN OFFICER AND A GENTLEMAN

(R8x32) 3C (4C set)

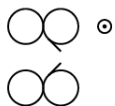
- 1-8 1s 1/2 turn RH, lead down middle to 3rd place & turn RH
- 9-16 1s dance reflection reels of 3 on opposite sides (1s up between 3s to start)
- 17-24 1s turn 3s on sides (1M+3L RH, 1L+3M LH), 1s lead up to top & cross & cast to 2nd q place
- 25-32 2s+1s dance R&L

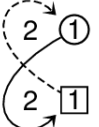
AN OFFICER AND A GENTLEMAN				8x32 R
T_R¹/₂  T_R	2 3 1 	 T_R  T_L		2 1 RL

David Tague, 1984, Fort Worden Decennial Dances

3C/4C longwise set

ASILOMAR ROMANTIC

(S8x32) 3C (4C set) Tom Cuthbertson, San Fransisco Collection 2

- 1- 8 1s+3s dance double Fig of 8 around 2s, 1s crossing down, 3s cast up to start
- 9-16 1s+2s dance Pousette
- 17-24 1s dance in and down between 2s (2s step up), set to each other and dance RSh round 4th corner to face own 1st corner
- 25-32 1s dance 'Hello-Goodbye' setting ending with petronella turn to 2nd places. 213

ASILOMAR ROMANTIC			8x32 S	
<p>Double Figure of 8</p>	<p>1 2</p> <p>P</p>	<p>S</p>		<p>S S S T \diamond</p>

Tom Cuthbertson, 1985, San Francisco Collection 2, RSCDS Thirty Popular Dances Vol 2

3C/4C longwise set.

MRS STEWART'S JIG

(J8x32) 3C (4C set) Frans Ligtmans, RSCDS Book 35

- 1- 8 1s set, 1L followed by partner casts 2 places, 1L crosses (below 3s) and casts up on Men's side to 2nd place facing down while 1M dances round 3L and up the middle to 2nd place Ladies' side facing down
- 9-16 2s+1s+3s dance Grand Chain, end with 2M and 1M facing out
- 17-24 2s+1s dance Ladies' Chain
- 25-32 2s+1s+3s advance and retire; 1s turn $1\frac{1}{2}$ RH to own sides. 213

MRS STEWART'S JIG			8x32 J	
<p>S</p>	<p>2 1x 3</p> <p>CHAIN</p>	<p>2 1x</p>		<p>T $R_{1\frac{1}{2}}$</p>





Frans Ligtmans, 1986, RSCDS Book 35.1

3C/4C longwise set.

THE ROBERTSON RANT

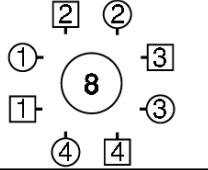
(S80) Sq.Set Mrs Douglas Winchester, RSCDS Book 39

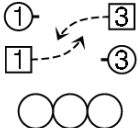
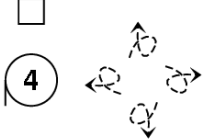
- 1- 8 All circle 8H round and back
- 9-16 All Ladies dance RH across $\frac{1}{2}$ way and turn opposite Man LH, all Ladies dance $\frac{1}{2}$ RH across and turn partner LH
- 17-24 1s+3s dance reel of 4 (Ladies start by passing LSh as Men set)
- 25-32 All set Highland Schottische to corners, turn 2H twice
- 33-40 2s+4s dance reel of 4 (Ladies start by passing LSh as Men set)
- 41-48 All set Highland Schottische to corners, turn 2H twice
- 49-56 All Ladies circle left to face partners (Ladies BtoB), set to and turn partners 2H
- 57-64 All Men circle right to face partners (Men BtoB), set to and turn partners 2H
- 65-72 All dance Grand Chain
- 73-80 All take allemande hold and dance anticlockwise once round set, bringing Ladies into center for bow/curtsy

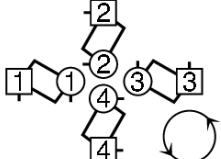
THE ROBERTSON RANT				80 S
			ALL HS T _{B2}	2 4 R 16 bars
	ALL S T_B		ALL S T_B	ALL CHAIN
				





Mrs Douglas Winchester, 1949, RSCDS Book 39.8

4C/4C square set.

SLEEPY MAGGIE

(R8x32) 3C (4C set) Alexander Bowman (1758), RSCDS Book 11

- 1- 8 1s+2s circle 4H round to left, 1s set and cast 1 place
 9-16 1s+3s dance RH across and LH back (1s end facing 1st corners)
 17-24 1s set and turn 1st corners, set and turn 2nd corners
 25-32 1s dance reels of 3 on opposite sides giving LSh to 1st corners and cross to places

SLEEPY MAGGIE				8x32 R
	S 	1 3 RA	1 3 LA	 X_R
				

Alexander Bowman, 1755, RSCDS Book 11.5

3C/4C longwise set.

Intermission

FT WORDEN FUN

(J8x32) 3C (4C set) Edith Chapman, Fort Worden XX

- 1- 8 1,2,3 mirror reels on the sides (written right shoulder with mirror optional)
 9-16 1's lead down and back
 17-24 1s set cast to 2nd place as 2's step up, 2.1.3 turn partner by the R hand all around
 25-32 Circle to left and back

MONYMUSK

(S8x32) 3C (4C set) Preston, RSCDS Book 11

- 1- 8 1s turn RH and cast to 2nd place (2s step up), turn 1¼ times LH (4 bars) to end 1L between 2s facing down, 1M between 3s facing up
- 9-16 2s+1s+3s set twice, 1s Petronella turn on second setting onto opposite sides (bars 11-12) and all set twice again on sides. 2(1)3
- 17-24 2s+1s+3s circle 6H round and back
- 25-32 1s dance reels of 3 on sides giving RSh to person on their Right (2nd corner) and 1s cross RH to places. 213

MONYMUSK				8x32 S	

Werner, 1785, RSCDS Book 11.2

3C/4C longwise set.

MAIRI'S WEDDING

(R8x40) 3C (4C set) James B. Cosh, 22 SCDs

- 1- 8 1s turn RH and cast to 2nd place (2s step up); 1s turn LH to face 1st corners
- 9-16 1s dance ½ diagonal reel of 4 with 1st corners, 1s dance ½ diagonal reel with 2nd corners
- 17-24 1s dance ½ diagonal reel with 3rd corner (positions), ½ diagonal reel with 4th corner (positions)
- 25-32 1s dance reel of 3 across (Lady with 2s, Man with 3s - LSh to 1st corner)
- 33-40 2s+1s+3s circle 6H round and back. 213

MAIRI'S WEDDING				8x40 R	

James Cosh, 1959, 22 SCDs, RSCDS Thirty Popular Dances Vol 2

3C/4C longwise set.

BLUE BONNETS

(J6x32) 2C (4C set) RSCDS Book 3

- 1- 8 1L+2M advance and retire and dance DoSiDo
- 9-16 1M+2L advance and retire and dance DoSiDo
- 17-24 1s lead down the middle and back
- 25-32 1s+2s dance Poussette. 2 1

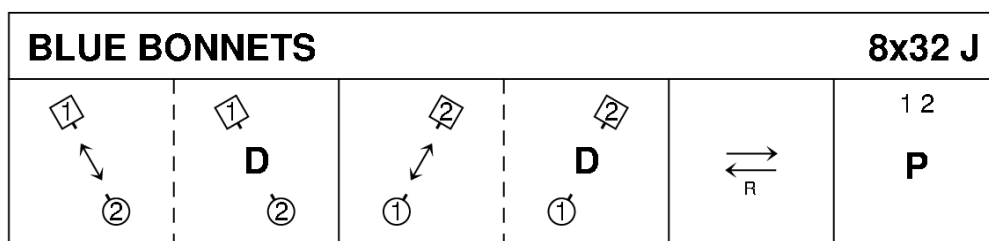

Allan, c.1900, RSCDS Book 3.5

2C/4C longwise set.

ANNA'S WEDDING CAKE

(S3x32) 3C set, Brenda Janssen, RSCDS Boston Celebrate 50 years

- 1- 8 1s turn 2H, cast 1 place, 1s dance ½ Figs of 8 (Lady round 2s and Man round 3s) 2(1)3
- 9-16 1s dance RSh across (Man with 2s and Lady with 3s), 1s dance ½ Figs of 8 (Lady round 2s and Man round 3s) 213
- 17-24 1s+3s dance set and rotate: Set, Rotate singly and dance on 1 place clockwise, change places RH on sides and dance on 1 place to own sides. 231
- 25-32 All circle 6H round and back

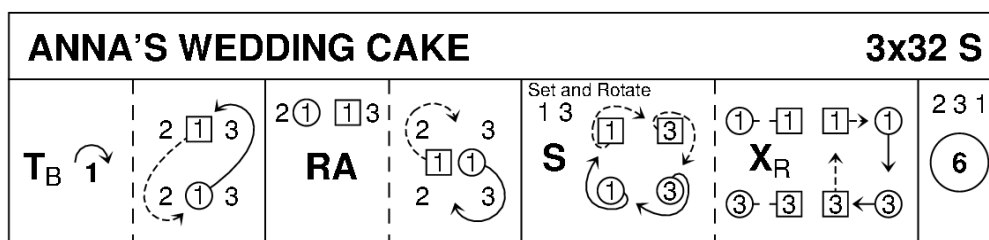

Brenda Janssen, 1996, Boston 50

3C/3C longwise set.

FERLA MOR

(R8x32) 3C (4C set) John Drewry, Deeside Book 1

- 1- 8 1s set, ½ turn RH to 2nd place opposite sides (2s step up), set and turn RH to end 1L facing her 1st corner with partner following
- 9-16 1s dance RSh Tandem diagonal reel of 3 with 1st corners end facing 3M
- 17-24 Repeat with 2nd corners 1s end by turning LH bars 23-24 to face own 1st corners
- 25-32 1s turn 1st corners RH (corners dance 4 bars), pass RSh to turn 2nd corners RH and cross RSh to place own side

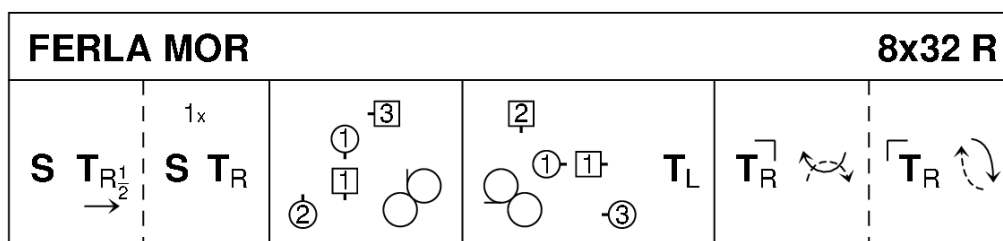

John Drewry, 1971, Deeside Book 1

3C/4C longwise set.